

Stair Treads

Tread Dimensions

Stairs treads have been so designed and manufactured as to be strong and nonslip for safe usage and good economy

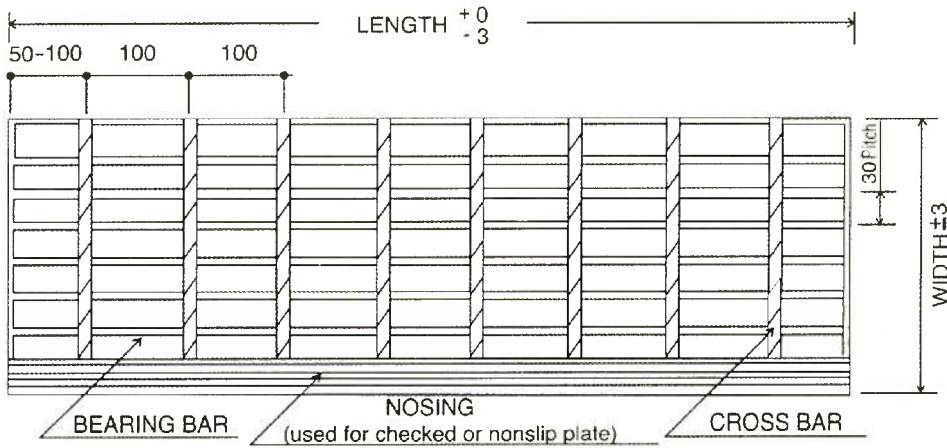

RECOMMENDED DIMENSION

Load bearing bars at 30mm pitch

WIDTH(mm)	215	245	275	305
BOLT PITCH(A)	120	150	180	210
LENGTH(mm)	500, 600, 700, 800, 900, 950, 1050, 1200			
Size of Bearing Bar(H)	I25, I32, F25×5, F32×5, SF25×5, F32×5			

WELDING TYPE

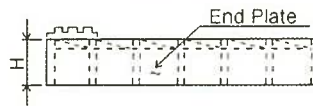

BOLTING TYPE

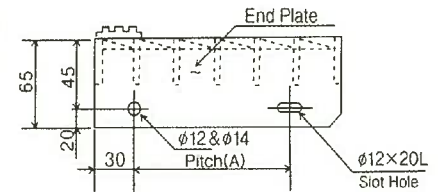

Installation

Installations are 2 Types (WELDING TYPE AND BOLTING TYPE)

Attaching by Welding

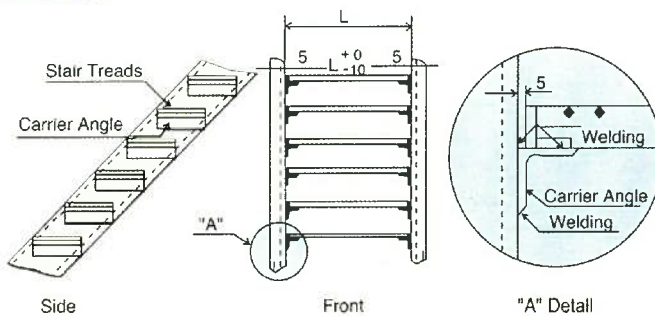

Fastening With Bolts

